

KONA

PRODUCT INFORMATION



A new level of play.

Rule Breaker. KONA



The all-new KONA redefines the standards of compact SUVs with future-oriented interior/exterior design based on Hyundai Motor Company's next-generation design identity, a cutting-edge new technology that transcends its class, and amenities that surpass its competitors.

C O N T E N T S

INTRODUCTION	02
EXTERIOR DESIGN	09
INTERIOR DESIGN	16
PERFORMANCE	27
HYUNDAI SMARTSENSE	42
CONVENIENCE	48
APPENDIX	52

Future-oriented design that strengthens KONA's unique design identity

EXTERIOR

Seamless horizon lamp emphasizing future-oriented image



- Front/rear seamless horizon lamps that provide differentiated images
- Sharp character lines in contrast with the simple side volume
- Armor-shaped unique wheel arch cladding design inheriting the uniqueness of KONA
- HMSL built-in spoiler with integrated chrome molding design that continues from the belt line and wraps around the entire spoiler

INTERIOR

Versatile driving space with emphasis on openness and usability



- Sporty layout with driver-centric design
- Emphasize slim and wide images with a horizontal crash pad of a floating shape
- Realization of high-tech indoor space through the application of cluster and AVNT integrated display
- Bench-type rear seat providing convenient usability

Best-in-class interior space and smart luggage space provide flexible space utilization

INTERIOR SPACE

Roomier rear seats and ample console storage



- Securing a wide console storage space by adopting a column-type electronic shift lever
- Provides flexible space utility features depending on the situation, such as a rotating cup holder

LUGGAGE SPACE

New features that provide maximized space utilization



- Rear seatback full-folding function that provides useful luggage space utilization with an improved folding angle close to flat
- Maximized storage convenience by applying the covering shelf storage and luggage board folding function

Equipped with advanced technology with an extra focus on comfort and functionality



- The all-new KONA offers the very best in comfort and convenience with highly versatile amenities like the Smart Power Tailgate and relaxation comfort seats
- Comes with the latest smart tech like cutting-edge connectivity features like BlueLink® Connected Car Services, which lets customer control their car from a smartphone

* Availability may differ by country & region

Highest level of safety and convenience-assisted ADAS features put the all-new KONA at the top of its class



Driving safety

- **BVM** (Blind-spot View Monitor) **NEW**
- **FCA** (Forward Collision-Avoidance Assist)
- **LKA** (Lane Keeping Assist)
- **BCA** (Blind-spot Collision-avoidance Assist)
- **BCW** (Blind-spot Collision Warning)
- **DAW** (Driver Attention Warning)
- **HBA** (High Beam Assist)

Driving convenience

- **ISLA** (Intelligent Speed Limit Assist) **NEW**
- **SCC** (Smart Cruise Control with Stop & Go)
- **LFA** (Lane Following Assist)
- **HDA** (Highway Driving Assist)
- **NSCC** (Navigation-based Smart Cruise Control)



Parking safety & convenience

- **SVM** (Surround View Monitor) **NEW**
- **PCA-R** (Parking Collision-Avoidance Assist-Reverse) **NEW**
- **RSPA** (Remote Smart Parking Assist) **NEW**
- **PDW-F/S/R** (Parking Distance Warning- Forward/Side/Reverse) **NEW**
- **RCCA** (Rear Cross-Traffic Collision-Avoidance Assist)
- **SEW** (Safe Exit Warning)
- **RVM** (Rear View Monitor)

IT'S STILL A KONA



EV-Derived futuristic design

EV-focused design as the designers began with the EV, with an intention to blur the line between the ICE and EV



Expressive characters

Maintain Kona's key design elements, such as unique C-pillar, composite light, cladding, and dynamic roofline.

HIGH TECH & DRIVER-ORIENTED



FLOATING & HORIZONTAL Interior architecture



Sporty & driver-oriented layout configuration



The floating crashpad with a horizontal layout alleviates the rather heavy feeling of an SUV by focusing on the slim & wide interior

EXTERIOR DESIGN

Realization of future-oriented exterior design where rugged and pure images coexist based on aerodynamic body profile

FRONT STYLE	10
SIDE STYLE	12
REAR STYLE	14



Realization of future-oriented and high-tech front image through the harmony of pure volume and seamless horizon lamp



FRONT DESIGN CONCEPT

- 1 Creating a simple and wide image by applying a seamless horizon lamp to the upper part of its voluminous front
- 2 The front bumper completed with a three-dimensional garnish and a bold skid plate creates a refined yet robust image
- 3 Elements inspired by rugged product design emphasize future-oriented yet SUV-like image

Light source composition

Seamless horizon lamp



Headlamp

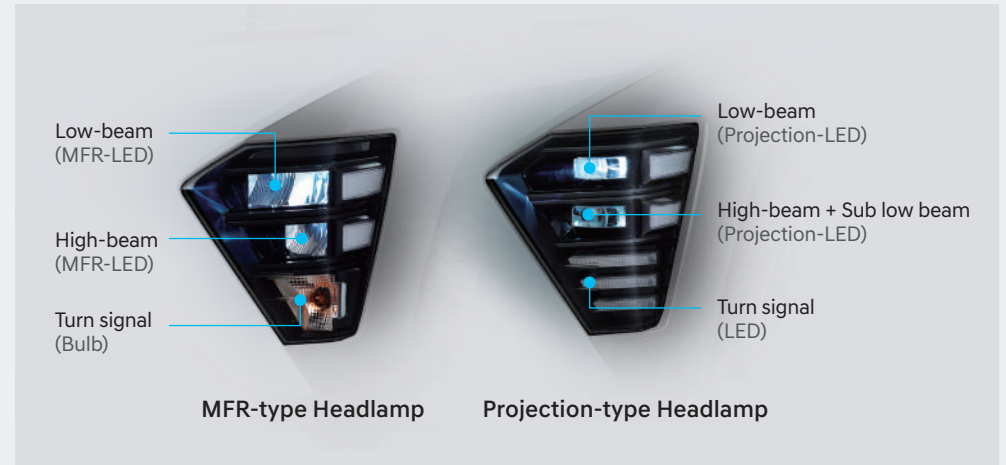

Seamless horizon lamp

Integrating the positioning lamp and DRL into a seamless line provides a future-oriented image when turned on



Headlamp

Separated headlamps, a signature of KONA, are designed with sophisticated details and edges that provide a sharp image



Front bumper

The three-dimensional garnish and skid plate of the front bumper offer a refined image







A sporty image is maximized by adding a sharp body character line and chrome molding to the dynamic side proportions.



SIDE DESIGN CONCEPT

- 1 Dynamic side proportion
- 2 Wheel arch cladding integrated with front and rear lamps inherits KONA's unique design
- 3 The chrome molding from the beltline to the rear spoiler is naturally connected to the body character line, creating a unique profile

Wheels & Tires

		16" Steel (Europe only)	16" Alloy (Europe only)	17" Alloy	18" Alloy		19" Alloy (Outside Europe)	
		Base model	Base model	Base model	Base model	<i>N Line</i>	Base model	<i>N Line</i>
Design								
Available model	ICE	●	●	●	○	○	○	○
	HEV		● (Europe)	● (General/Middle East/ Australia)	○	○		
Color		CLEAN SILVER (CS)	STEEL GRAY (XGM)	STEEL GRAY (XGM)	GLOSSY BLACK (NGB)	METALLIC (R8A)	GLOSSY BLACK (NGB)	METALLIC (R8A)
Tires		205/65R16		215/60R17	215/55R18		235/45R19	



Wheel arch cladding

By visually integrating with the front and rear lamps, KONA's uniqueness and rugged SUV image are emphasized at the same time.



Belt line chrome molding

The chrome molding from the belt line to the rear spoiler is visually connected to the body character line to maximize the sporty image



Outside mirror

Two-toned wing mirror with a sporty shape that harmonizes with the side design

The voluminous rear view and seamlessly connected horizontal lamps give a sense of unity with the front design



REAR DESIGN CONCEPT

- 1 The voluminous rear view and seamlessly connected horizontal lamps give a sense of unity with the front design
- 2 HMSL integrated with chrome molding that continues from the beltline and wraps around the entire spoiler
- 3 Skid plate with an iconic and solid shape

Light source composition

Seamless horizontal lamp & Lower lamp

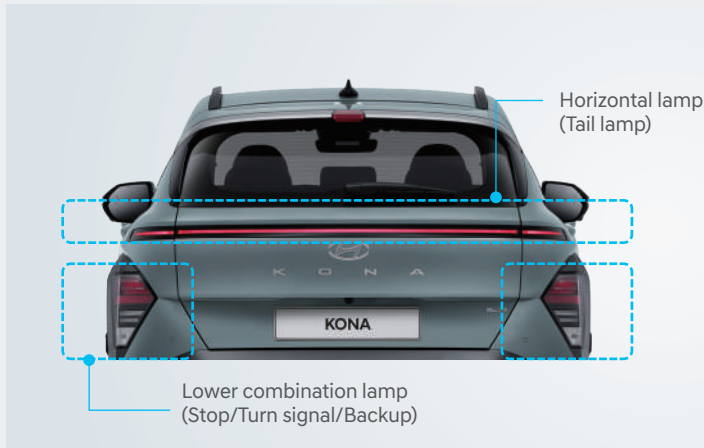

Seamless horizontal lamps, our next-generation signature lighting, are applied to the rear as well as the front to maximize the future-oriented image, and lower combination lamps with Stop/Turn signal /Backup lamp functions are applied to the lower lamp

Light configuration of Lower lamp

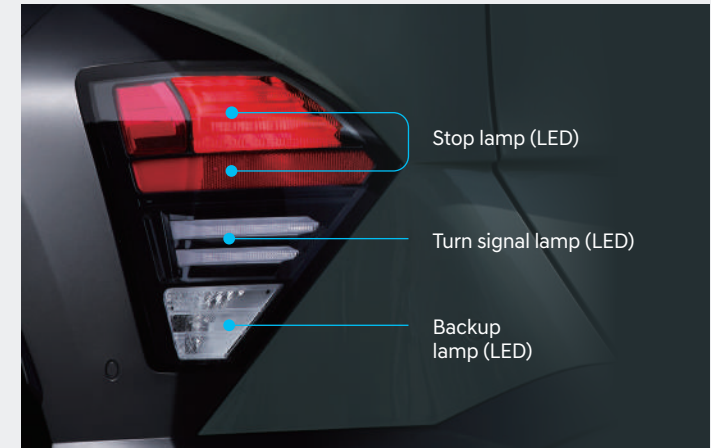

Lower combination lamp

The bold SUV image is visualized by applying a wedge-shaped combination lamp integrated with the wheel arch cladding to the lower area



Rear spoiler with *HMSL

The design that lights up even the upper part enhances the three-dimensional look and KONA's unique design identity.

*High Mounted Stop Lamp



Tailgate

Pursuing a refined luxuriousness and stable look by minimizing decorative elements along with a horizontal tail lamp applied to an elegant curved surface

INTERIOR DESIGN

Futuristic and exceptional usability is realized with the cluster and AVNT integrated display, column-type electronic shift lever, Open type clean console, etc.

DRIVER SPACE	17
INTERIOR SPACE	19
PACKAGE	20
N LINE	24

High-tech driver space designed with a horizontal crashpad layout and driver-oriented interface



Driver space design concept



- 1 Applying a floating horizontal crash pad layout to realize a slim and wide image
- 2 Driver-oriented high-tech layout consisting of a 12.3-inch dual-wide display that integrates cluster and navigation
- 3 Open-type console storage that remarkably improves usability and storage by applying an electronic shift lever (column type)

Improved console usability



The open console storage expands the storage space of the floor console and provides maximized practicality and various conveniences.

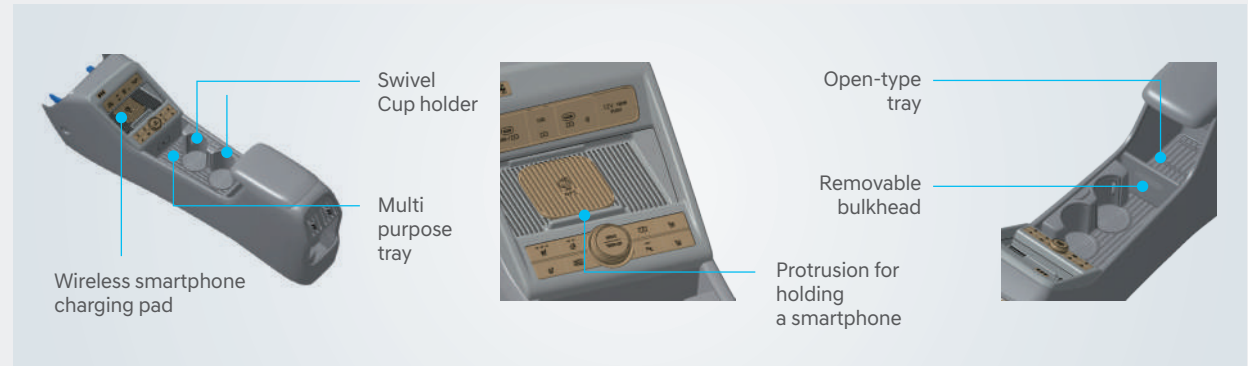

Significantly improved storage convenience for small items by applying a horizontal wireless charging pad, a large-capacity open tray, and a rotating cup holder

12.3-inch dual wide display



Realization of high-tech driver-centered layout by applying an all-in-one large screen display that integrates the instrument cluster and navigation

Electronic shift lever (column type)



The electronic shift lever mounted on the steering column provides effortless controllability

Enhanced usability and luxury with a variety of convenience features that are considerate to passengers



Knobless inside door handle

The inside door handle adopts a sophisticated Knobless design and applies a 2-motion override to the front passenger and rear door to prevent door opening while driving



Wireless charging pad

High-speed wireless charging function and built-in cooling fan to prevent overheating enhance convenience and safety when charging smartphones



Type-C USB charging port

Reduced charging time and improved convenience by changing the existing A-type USB charging terminal to the latest C-type that enables high-speed charging



Integrated memory system (IMS)

Provides convenience by automatically adjusting the driver's seat to the set position with a simple button operation



1st-Row Relaxation Comfort Seats

Relaxation comfort seats are applied to the driver's and front passenger's seats to support comfortable rest in a zero-gravity position when the vehicle is stopped



2nd-row seatback 2-step latch

The tilting angle of the rear seat back can be adjusted in 2 steps (26° / 32°) to provide comfortable seating

* Availability may differ by country & region

Strengthened interior space competitiveness by increasing dimensions such as overall length and overall height

Increased overall length

by **145mm**

- Front overhang - 10 mm
- Wheelbase +60 mm
- Rear overhang +95 mm

Increased overall height

by **30mm**

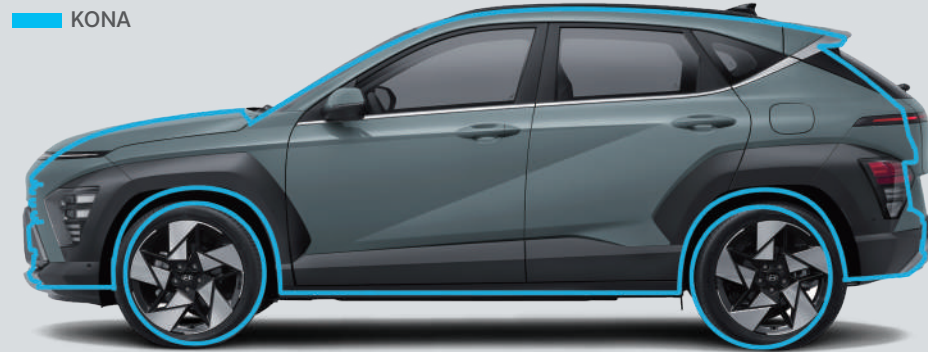

860(-10)	2,660(+60)	830(+95)
4,350(+145)		



1,825(+25)

[w/ Roof rack : 1,615]

1,580(+30)

Exterior dimension comparison

Unit : mm

		KONA	Diff.	The all-new KONA	Diff.	VW T-ROC	Honda HR-V
Overall length		4,205	+145	4,350	+116	4,234	4,295
Overall width		1,800	+25	1,825	+6	1,819	1,777
Overall height		1,550	+30	1,580	+25	1,545	1,577
Wheelbase		2,600	+60	2,660	+70	2,590	2,610
Overhang	Front	870	-10	860	+29	831	867
	Rear	735	+95	830	+27	803	807

Best-in-class rear seat space with maximized shoulder and leg room

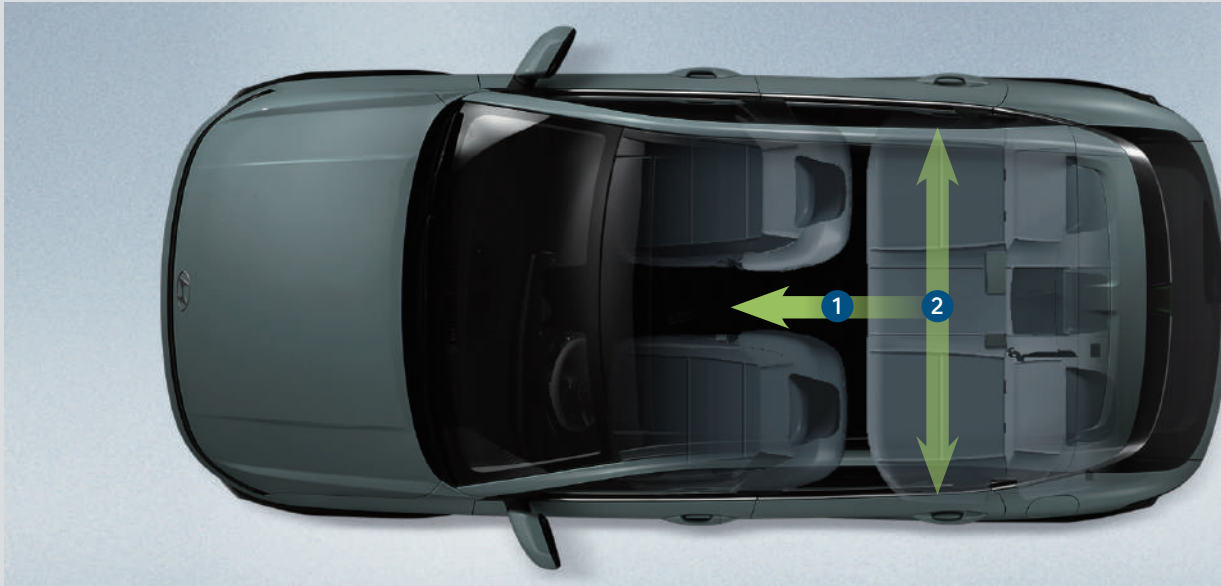

Increased space in the second row seats

✓ Best-in-class 2nd-row seat's leg room

970 mm

✓ Largest 2nd-row seat's shoulder room in its class

1,402 mm

2nd-row seat space comparison

Unit : mm

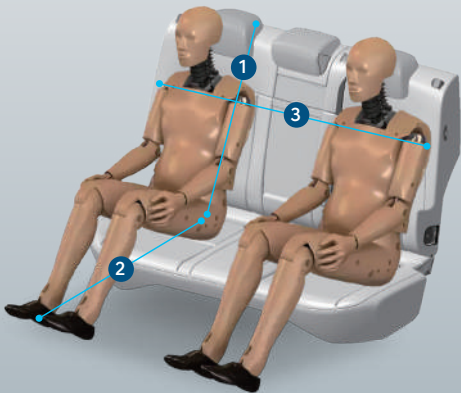

		KONA	The all-new KONA	VW T-ROC	Honda HR-V
1 Head room	Front	1,005	1,015	1,023	986
	Rear	961	972	976	967
2 Leg room	Front	1,054	1,059	1,059	1,050
	Rear	893	970	877	955
	Total	1,947	2,029	1,936	2,005
3 Shoulder room	Front	1,410	1,435	1,415	1,448
	Rear	1,385	1,402	1,391	1,390

Realization of best-in-class cargo space through space optimized design reflecting customer needs and application of new functions

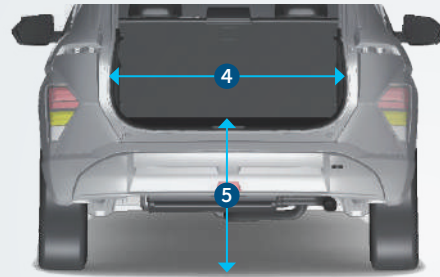
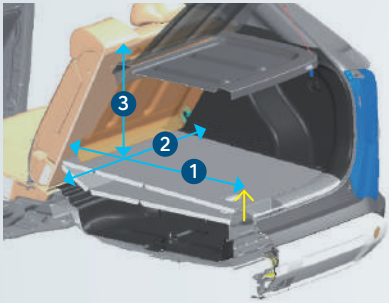

2 x golf bags + 4 x Boston bags



466 Liter (VDA)

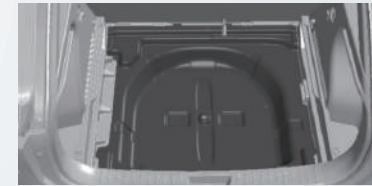

Mat applied to tire well.

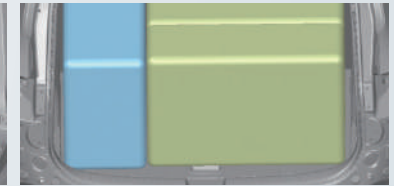

Fits 3 x 28-inch suitcases

Major cargo design improvements

- ✓ The 2-step board that prevents lower panel exposure and the NVH improved pad applied
- ✓ Improved loading convenience by lowering the loading height and increasing the opening width
- ✓ Loads up to 2 x golf bags + 4 x Boston bags, and 3 x 28-inch suitcases

Luggage Space comparison

Unit : mm

			KONA	The all-new KONA	VW T-ROC	Honda HR-V
Luggage space	Length	①	695	867	828	808
	Width	②	966	1,042	1,100	1,005
	Height	③	532	719	633	600
Opening width		④	1,002	1,040	1,149	1,161
Loading height		⑤	695	676	754	691
Luggage volume	VDA (ℓ)		374 (2WD) / 361 (4WD)	466	442 (2WD) / 392 (4WD)	469

Best-in-class cargo space, as well as maximized luggage storage convenience through new luggage space features



- ✓ 2nd-row seatback full-folding function that enhances outdoor usability such as car camping
- ✓ Covering shelf storage function and luggage board folding function for easy loading of bulky cargo
- ✓ Provides additional storage space in the tire well space under the luggage board

Enhanced cargo space utilization

Default position

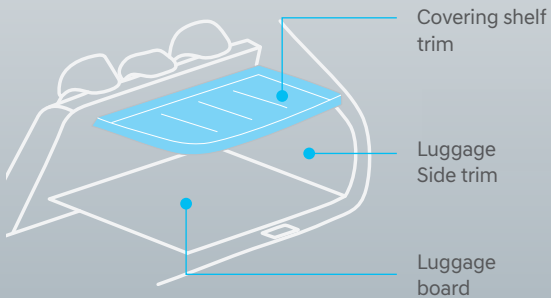

Application A

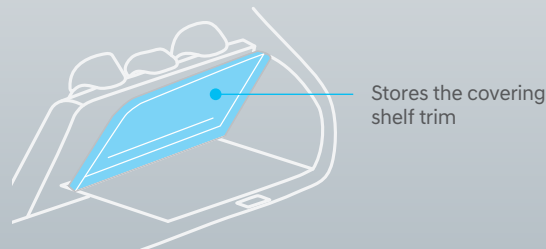

The covering shelf can be stored in the rear seatback to improve convenience when loading bulky cargo

Application B



When the luggage board is folded and fixed while the covering shelf is stored, it improves the convenience of loading tall cargo or storing bulky boxes and travel carriers



N Line-exclusive exterior design features

- 1 Completion of an aggressive front image with a bold and three-dimensional garnish
- 2 Concentrate on a low and stable stance with a wing-shaped design that wraps around the lower part of the bumper, which is the N-Line design identity
- 3 The N-line exclusive silver garnish line that wraps 360 degrees around the lower part of the vehicle and the side skirt design makes the body look lower and exude a high-performance image
- 4 Add-on-type wing spoiler that enhances aerodynamic performance and visualizes high-performance images

Differentiated exterior design items



Body-colored cladding



Front bumper & Bumper skirt



N Line-exclusive 19-inch alloy wheel



Side skirt



Wing-type rear spoiler

※ The standard rear spoiler is applied in the European market



Single twin tip muffler



N Line-exclusive interior design features



Exclusive steering wheel



Exclusive seats



Metal pedals



Metal door scuffs



Red color points



Dark chrome switches & moldings

PERFORMANCE

Adopting the new 3rd generation platform provides a comfortable ride and sophisticated handling performance suitable for an urban SUV, as well as NVH performance that transcends its class and enables differentiated emotional driving

POWERTRAIN	28
HEV	30
BODY STRUCTURE	34
COLLISION SAFETY	35
RIDE & HANDLING	36
NVH/AERODYNAMICS	39



Provides differentiated driving characteristics such as powerful acceleration performance and best-in-class fuel economy

Engines

Gamma II 1.6 T-GDI

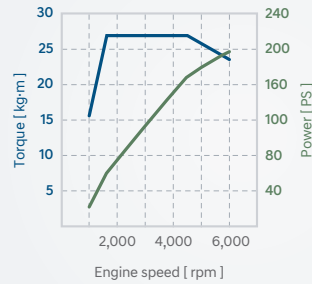
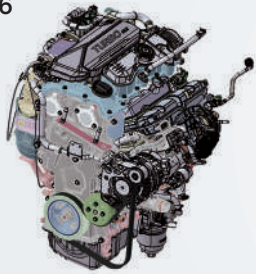

Max. Power (PS@rpm) **198** @6,000
*193 @6,000



Max. Torque (kgf·m@rpm) **27.0** @1,600
*27.0 @1,750

*North American specifications

G4N III 2.0 MPI Atkinson

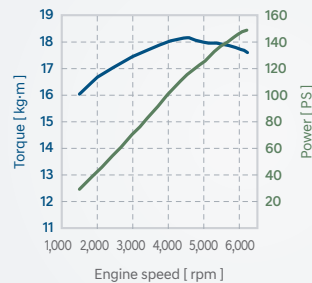
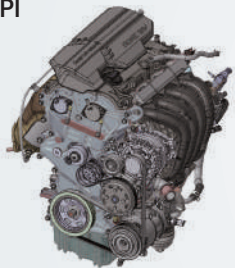

Max. Power (PS@rpm) **149** @6,200



Max. Torque (kgf·m@rpm) **18.3** @4,300

Improved Kappa 1.0 T

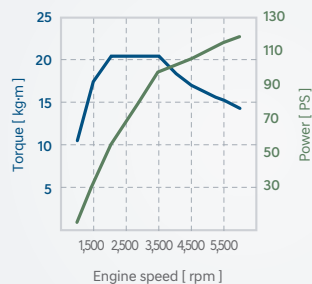
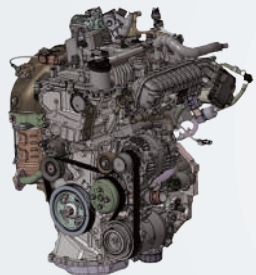

Max. Power (PS@rpm) **120** @6,000



Max. Torque (kgf·m@rpm) **20.4** @2,000

Mated T/M

7DCT



Europe

8-speed A/T



North America



IVT



North America



6-speed M/T

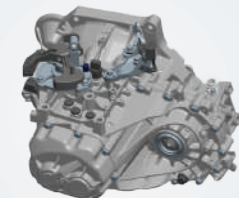



Europe



Powertrain lineup comparison w/competitors

* SX2 : 2WD based
 ** HR-V, T-ROC : old model based

		The all-new KONA				Honda HR-V	VW T-ROC	
								
		Europe		North America				
		Improved Kappa 1.0T	Gamma II 1.6T	Improved Nu 2.0	Gamma II 1.6T	1.8MPI	1.0T GDI	1.5T GDI
Engine	Max. power (PS)	120/6,000	198/6,000	149/6,200	193/6,000	141/6,500	115/5,000	150/6,000
	Max. torque (kgf-m/rpm)	20.4/2,000	27.0/1,600	18.3/4,300	27.0/1,700	17.6/4,300	20.4/2,000	25.5/1,500
Transmission		6MT	7DCT	CVT	8AT	CVT	6MT	7DCT
		Final gear ratio #1/2		6.052		5.436	-	-
		N/V ratio		127.5		113.5	139.9	135.1
		1st		130.1		18.3	23.7	18
		TOP		17.5		188	186	195
		180		210		10.9	10.5	9.5
		210		192		7.9	15.9	6.4
		11.8		10.2		-	136	142
		7.8		8.1		30	-	-
		15.5		6.9		-	-	-
		5.1		5.3		-	-	-
Fuel economy	Europe	CO ₂ (g/km)	123	143	-	-	136	142
	North America	mileage (mpg)	-	-	32	28	-	-

Realization of a high-efficiency, high-output hybrid powertrain by applying an improved hybrid-dedicated system

Improved Kappa 1.6 GDI

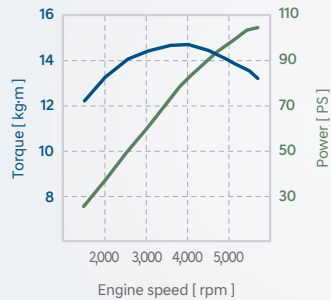
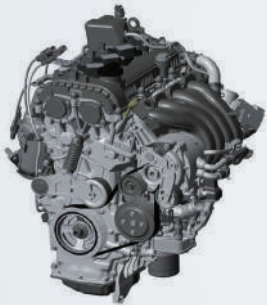

Max. Power
(PS@rpm)

105 @6,000



Max. Torque
(kgf·m@rpm)

14.7 @1,600-4,500

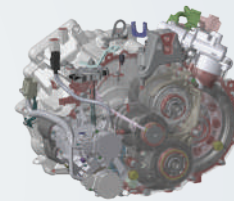

Mated with
6-speed DCT

Combined output of engine/motor	141 PS
Engine	G4LIII 1.6GDI
Transmission	6DCTgen2 (permissible torque : 27 kgf·m)
Drive motor	32 kW (permanent magnet type)
High voltage battery	1.32 kWh (lithium-ion battery)

e-Motion Drive (Electrified motor-based driving performance improvement technology)



Provides improved stability and dynamic driving performance by applying e-Motion Drive, which alleviates instability caused by understeer and braking control while the vehicle is turning through partial braking and drive motor torque compensation control

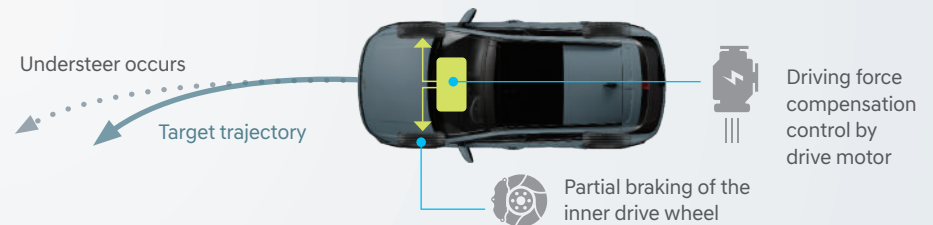

Aerodynamic performance

Center floor undercover

Compared to the ICE model, the lower flow is improved by extending the coverage range of the center floor undercover

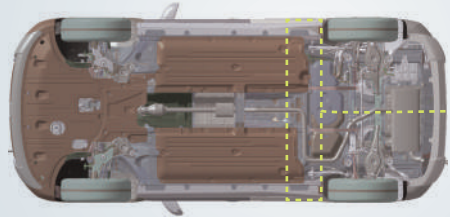

Extended undercover coverage



Active Air Flap (AAF)

Compared to the ICE model with an external AAF applied only on the top, the hybrid model adds a built-in AAF to the bottom to minimize air resistance and improve fuel economy

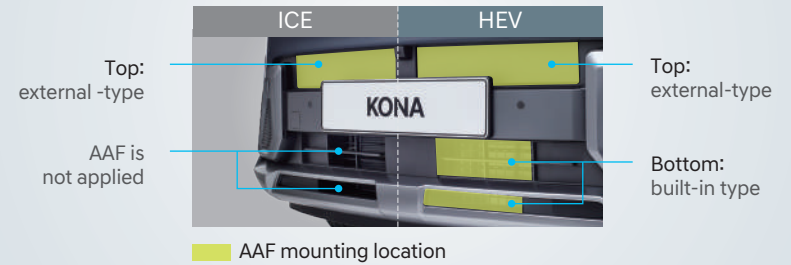

Multi-link rear suspension

Application of a multi-link type rear suspension that provides stable grip and minimizes vibration transmitted to the body to provide excellent riding comfort and stable driving characteristics

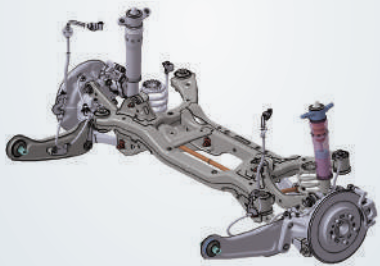

Paddle regenerative braking system



The level of regenerative braking can be adjusted in 3 steps with the paddle shift mounted on the left and right rear of the steering wheel, providing convenience and improving fuel efficiency depending on the driving situation.

※ New function : Complete stop function

Provides a complete stop function using regenerative braking of the vehicle without operating the brake pedal when the (-) lever is pulled for more than 0.4 seconds

		Function (Eco Mode Only)
Paddle +/-operation		Function to adjust regenerative braking in 1 to 3 steps
long operation	(-)	Maximum regenerative braking & complete stop (vehicle speed = 0km/h) function
	(+)	ON/OFF the intelligent regenerative braking 2.0 function. Regenerative braking can be adjusted from 1 to 3 steps when operating the paddle afterward.

Smart Regenerative Braking 2.0

Class first

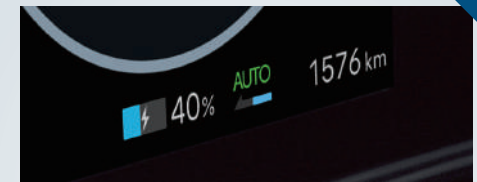

When coasting without stepping on the accelerator pedal, the function automatically controls the regenerative braking step according to the road slope and the driving situation of the vehicle ahead. It automatically decelerates using the route information (speed camera) and the navigation when setting the destination. Minimizes unnecessary brake and accelerator pedal operation to increase energy efficiency and improve convenience by reducing driving fatigue

HEV Powertrain comparison w/ competitors

		SX2 HEV		KONA HEV (16/18-inch)	Toyota C-HR HEV	Honda HR-V HEV
						
		16-inch (Europe)	18-inch (Europe)			
Engine	Type	Improved Kappa 1.6GDI		Kappa 1.6GDI	1.8 Atkinson	1.5L
	Max. power (PS)/ Max. torque (kgf·m)	105/14.7		105/15.0	99/14.5	107/13.4
Transmission	Type	D6KF1-2		D6KF1	eCVT	eCVT
	FGR 1/2	4,438/3,227		4,438/3,227	-	-
Motor (Nm/kW)		170 / 32		170 / 32	163 / 53	253 / 96
Battery capacity (kWh)		1.32 (240V/5.5Ah)		1.32	-	-
Performance	Top speed (km/h)	161(Eco) 165(Sport)	155(Eco) 165(Sport)	165/161	169	169
	0 → 100kph(Sec.)	10.9	11.2	11.0/11.3	11	10.4
	80 → 120kph(Sec.)	8.0	8.8	8.5/8.9	-	9.3
Fuel economy (Europe)	CO ₂ (g/km)	103	108	114/122	110	122

3rd generation platform



Great Flexibility

Securing chassis and powertrain adaptability with integrated ICE/HEV/EV platform



Enhanced suspension performance

Improved steering feel (improved steering gearbox position) and improved NVH (improved mounting structure)



Enhanced collision safety

Securing stable front crash performance by applying multi-load path



Reflecting SUV concept and expanded interior space

Applied platform structure with increased overall width and tire size/Improved rear seat comfort and increased cargo space

Application of the 3rd generation K-platform that maximizes safety and space efficiency for each powertrain through modular design

Multi load-path

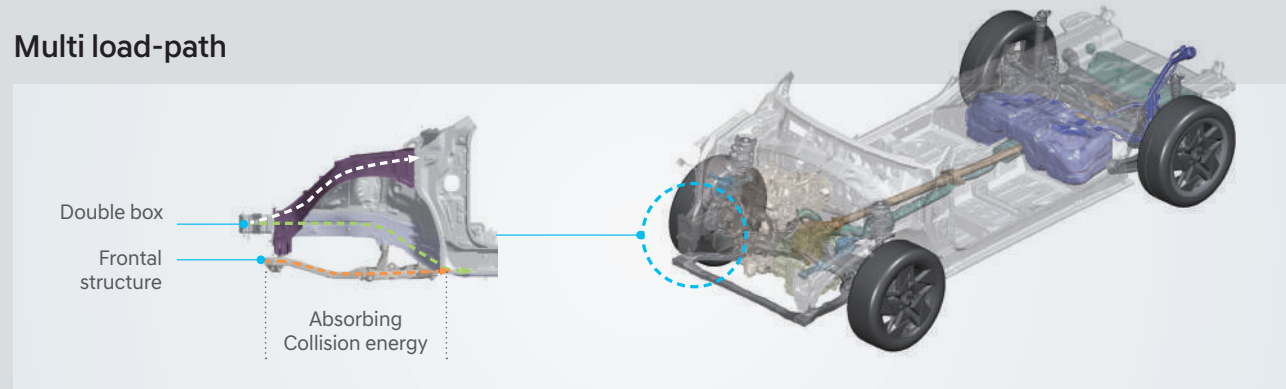

KONA

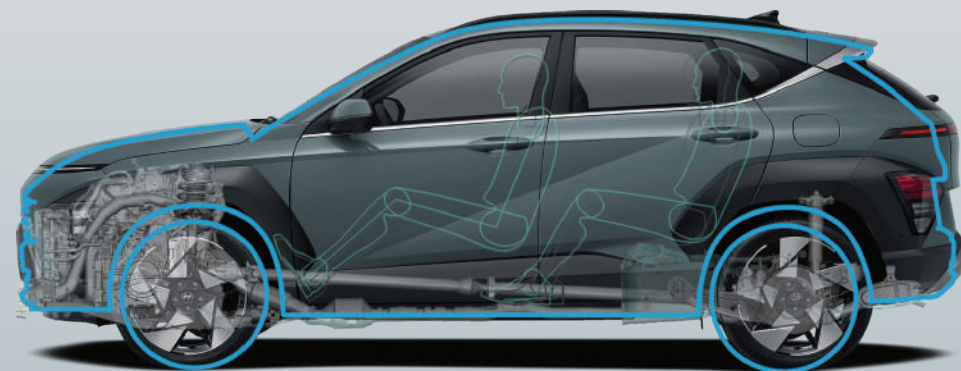

Unit : mm

1,580(+30)

860(-10)	2,660(+60)	830(+95)
4,350(+145)		

Our first 180K class TWB process application and 50% increased hot stamping parts minimize deformation of cabin space in case of collision

Hot-stamping processed parts

For the first time in HMC, the customized cutting and welding (TWB) process of 180K class ultra-high-strength material is applied, and the number of hot stamped parts increased by 50% compared to the KONA, and the average tensile strength is increased by 10%

Application area for hot stamping parts
 = 50% increase compared to the KONA

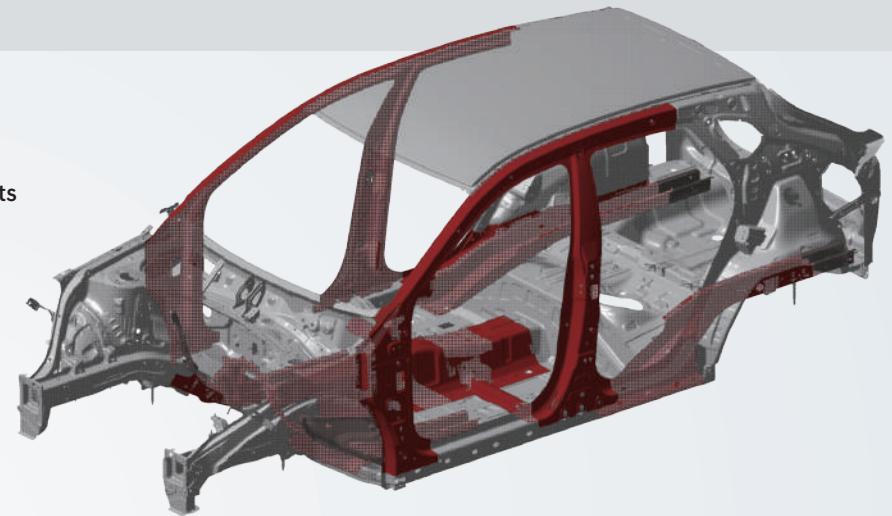

Expanded application of 180K/150K class hot stamping parts

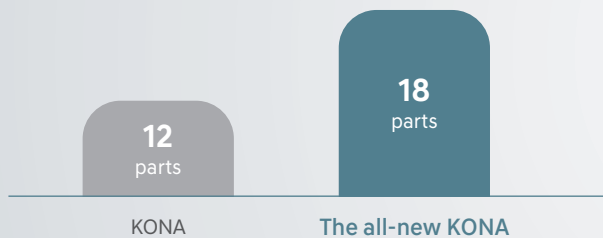

Average tensile strength comparison

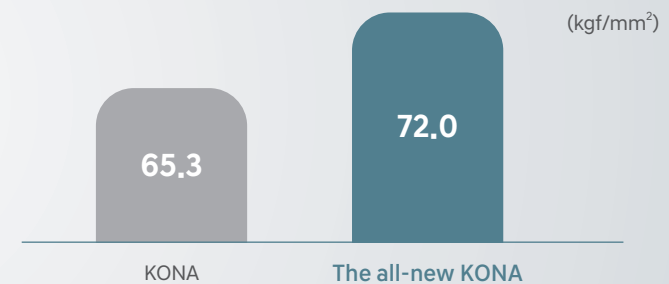

Securing best-in-class crash safety by implementing a high-rigidity body through a crash energy dissipation structure and rigidity-increased design

Optimizing the strength/thickness of the side outer stiffeners

KONA → The all-new KONA

150K(1.2t) → 150K(1.6t/1.2t), 150K(1.6t), 120K(1.2t)

✓ Securing collision robustness by optimizing the thickness of the main member

Application of front side member with dual member structure

KONA → The all-new KONA

✓ Improving front crash performance by applying a load distribution structure

Improved connectivity between the top and bottom of the center pillar reinforcement

KONA → The all-new KONA

Increase the reinforcement section

✓ Crash load dispersion structure corresponding to IIHS SIDE 2.0

180K/80K TWB processed rear floor member

KONA → The all-new KONA

150K integral type → 180K, 80K

Multi Collision Brake (MCB)



Multi Collision Brake is a system that applies the brakes to prevent or mitigate a subsequent impact when a vehicle has been involved in a collision

6-Airbag system



The all-new KONA comes with a total of six airbags, including first-row advanced airbags, side airbags, and side curtain airbags, to minimize occupant injuries in the event of a collision

Steering performance

Improved steering reliability by applying motor + ECU integrated power pack type C-EPS



Application effect of Power pack-type C-EPS

Light weight and high efficiency by applying motor and ECU integrated power pack

Application of security features related to cyber security and support for future S/W updates through OTA

Configuration of steering system (C-EPS)

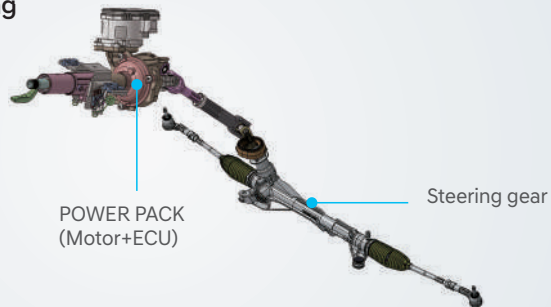

Brake performance

Securing reliable braking feel and braking distance / Standardization of EPB

Brake feel

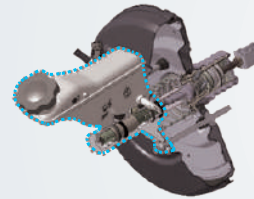

Applying a braking system that improves braking feel and vehicle body control reliability

- ✓ Improvement of initial braking feel : Reduced booster jump-in characteristics (50 → 40kgf)
- ✓ Securing controllability in the middle and second half of braking : Reduced booster power ratio (10:1 → 9:1)

Braking distances

Securing equivalent or better braking performance (braking distance) than competitors

CR ※ North American CR braking distances (60mph dry road comparison)

Auto Bild ※ Europe AB braking distances (Compared to 100kph Cold)

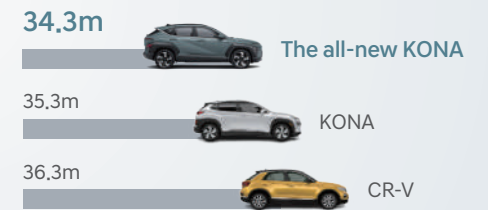
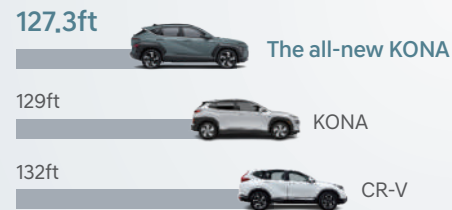

Braking Convenience



EPB (Electronic Parking Brake) linked to AVH and ISG is applied as standard to all models to improve convenience

Suspension performance

Optimally tuned front/rear suspension realizes stable driving feeling and agile performance even under extreme driving conditions



Application of Hydro CTBA Bush

- ✓ Hydro bush applied for the first time in CTBA

Improving driving vibration, impact and aftershock

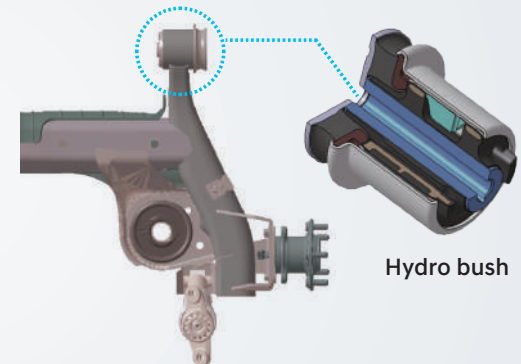

Front suspension

McPherson strut-type

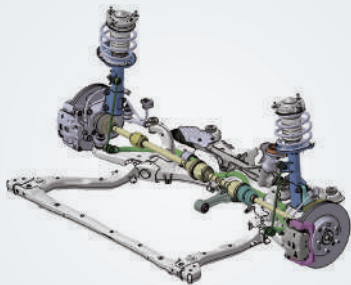

Application of frontal structure (impact-bar) to secure crash performance

Rear suspension

CTBA-type (2WD model)

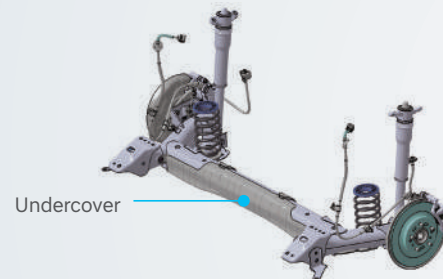

Exclusively for 2WD, undercover applied to improve aerodynamics

Multi link-type (4WD & HEV models)

4WD

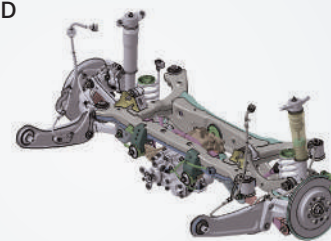

HEV

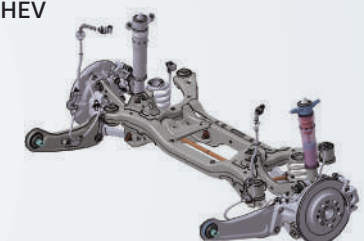

2-types of rear wheel suspension applied to 4WD & HEV models (4WD, HEV: applied multi-link type)

HTRAC (Electronic all-wheel drive system)

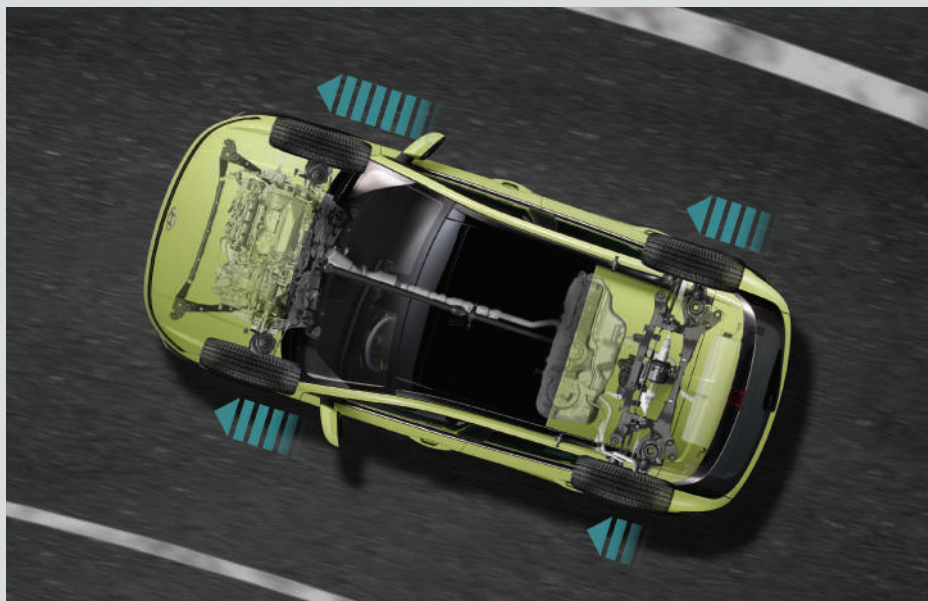

The HTRAC 4-wheel drive system actively distributes driving force to the front and rear wheels according to various driving conditions to achieve optimal driving performance

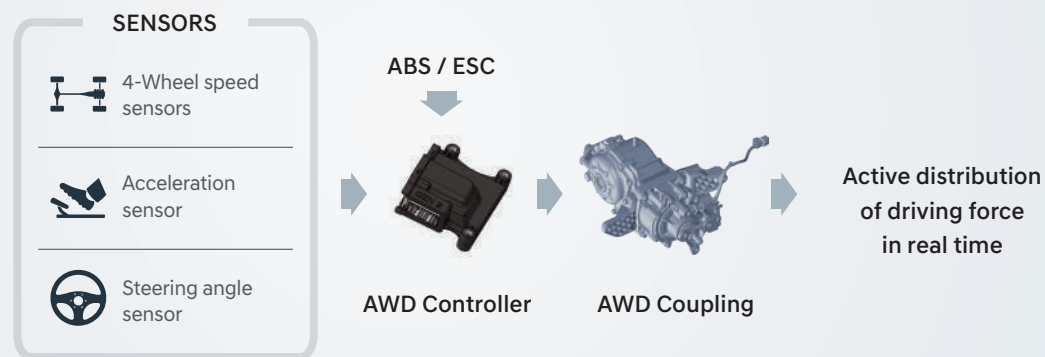

TERRAIN Mode



TERRAIN Mode provides optimal driving performance not only on road but also on rough terrains by controlling driving power, engine torque, and braking force in an integrated manner according to terrain conditions such as snowy roads



Operating terrain mode

- ① Activate [TERRAIN] mode by pressing the jog dial
- ② Change mode by operating the dial left or right
- ③ The graphic for the mode is popped up on the cluster

Realization of best-in-class quietness by optimizing sound-absorbing and insulating materials, improving and strengthening body design



N.V.H. Performance comparison

Category		KONA	The all-new KONA			Seltos PE
			1.6T	2.0	HEV	
Acceleration	Interior noise (dBA)	54	53	53	53	54
Road noise (dBA)		65	64			65
Wind noise	Wind tunnel Interior noise (dBA)	65.3	64.7			65.0

Minimize road noise

Driving quietness improvement design

Floor carpet underpad

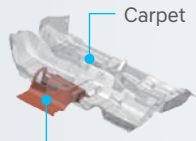

Sound absorbing pad

Reduction of external noise by applying an under pad to the floor carpet

Acoustic tires (19-inches only)



Sound absorbing pad

Minimize tire resonance by applying sound-absorbing pads inside the tire

Rear wheel member bushing



(Multi-link models)



Member bushing

Minimizing the inflow of road surface vibration by applying member bush

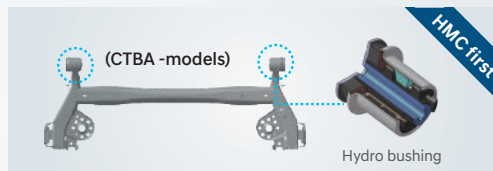

Significantly improved driving vibration and shock transmission by applying hydro bush

Minimize wind noise

Minimize wind noise and improve shielding

Minimizes wind noise by applying sound-insulating glass to the windshield and cut-line seals on the outside mirrors

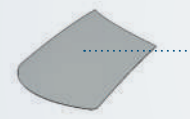

Double laminated sound insulation glass

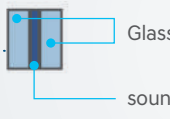

Glass

sound insulation film



Cut-line seals on the outside mirrors

Reinforced sealing prevents wind noise from entering the room

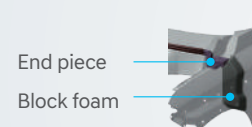

End piece

Block foam



Hood weather end piece/fender top block foam

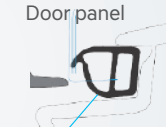

Door panel

Side garnish

Side lower seal

Provides stable high-speed driving performance and fuel efficiency improvement through careful aerodynamic design

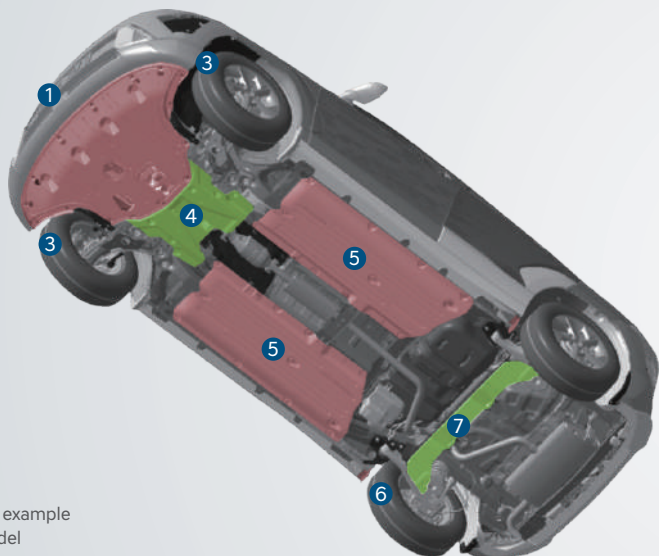

Underbody aerodynamic design

Improvement of aerodynamic performance by applying additional aerodynamic items compared to the KONA to the under part of the body

Common application area with KONA

- ① Front bumper lip
- ② Engine room undercover
- ③ Front wheel deflector
- ⑤ Center floor undercover
- ⑥ Rear wheel deflector

Additional/improved items compared to the KONA

- ④ Front subframe undercover
- ⑦ CTBA undercover (※ Not applied to 4WD models)

※ Image is an example of 2WD model

Upperbody aerodynamic styling

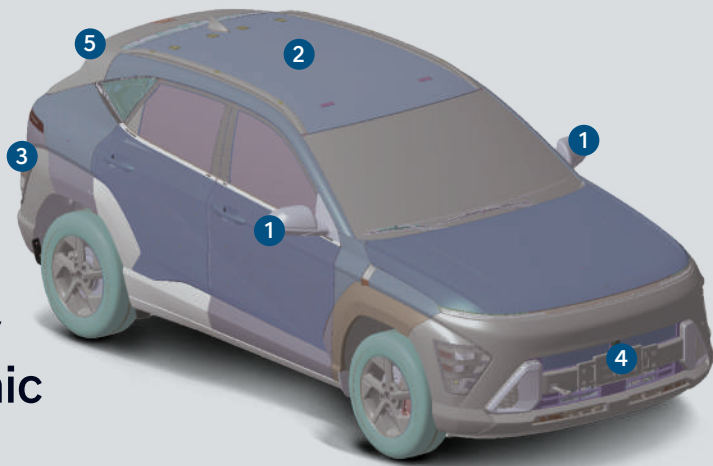

1 Optimized aerodynamics of outside mirror

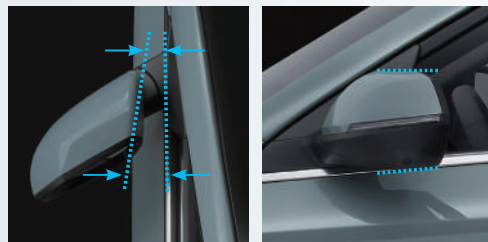

Applying a diffused structure that widens the gap between the inside of the mirror housing and the glass toward the rear, and a flattened upper and lower rear section

2 Roof inclination angle optimization / boat tail shape



- ✓ Applying an aerodynamic roof profile while securing 2nd row interior space
- ✓ Optimization of up/down, left/right flow balance by applying boat tail shape

3 Tail/rear lamp stripping trap

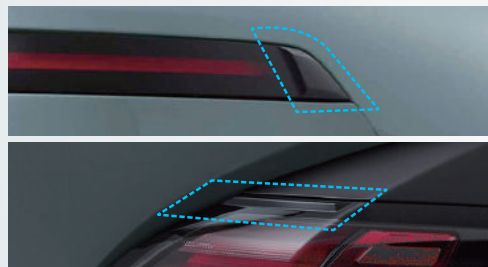

A stripping trap, which helps the air to flow smoothly by arranging the airflow, is applied to the side of the rear tail lamp and the top of the rear combination lamp to minimize turbulence and reduce air resistance

4 External-type Active Air Flap (AAF)



AAF Opened

AAF Closed

- ✓ Implementing a refined exterior image and reducing cooling resistance
- ✓ Improvement of vehicle air resistance, when closed, compared to when open

5 Balanced rear spoiler/side garnish



Realization of the shape of the rear spoiler and side garnish considering the vertical and horizontal balance of air flow

HYUNDAI SMARTSENSE

The updated driver assistance system, which is one step closer to autonomous vehicles of the future, provides enhanced safety and convenience, including best-in-class driving and parking safety features.



Features that assist the safety and convenience of vehicles and passengers in various driving situations



Forward Collision-avoidance Assist (FCA)

If a collision with another vehicle, pedestrian or cyclist is anticipated through analysis of information through the front radar and camera, warning signals and automatic braking assist the driver to avoid or mitigate an accident

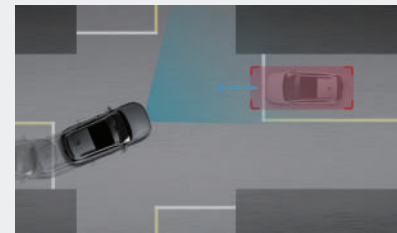

FCA-JT (Junction Turning) feature

FCA-JT expands the range of protection to include collisions at junctions. FCA-JT detects the oncoming car from the other side when turning left at a junction and, if a collision appears likely, applies the brakes to stop the car.

NEW

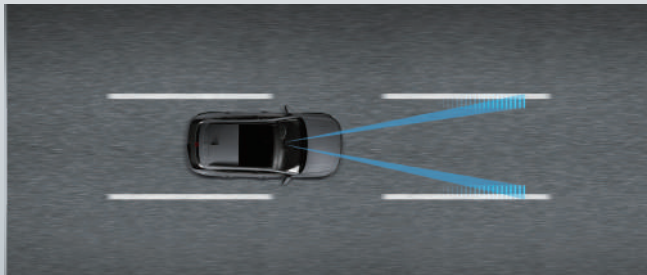

Lane Keeping Assist (LKA)

Warns if a lane departure is detected without a turn signal switch on. Automatically assists steering to prevent the vehicle from departing the lane only if lane departure is detected without a turn signal switch on.



Lane Following Assist (LFA)

Using a front view camera, the system recognizes lane markers and vehicles to steer the vehicle to the middle of the lane.



Intelligent Speed Limit Assist (ISLA)

Warns if driving over the speed limit of the road using the information of the front view camera or navigation.

※ Availability may differ by country & region

Navigation-based Smart Cruise Control (NSCC)



NSCC is a system that improves driving convenience through deceleration control in speed limits, curves, and ramp sections on highways while driving with SCC activated.

Highway Driving Assist (HDA)



HDA is a driving convenience system that maintains the distance and lane from the vehicle ahead and helps to change lanes safely.

BCA (Blind-Spot Collision-Avoidance Assist)



BCA automatically assists braking while changing lanes if the risk of collision with vehicles in the blind-spot is detected. BCA automatically assists braking while driving forward to exit a parallel parking spot if the risk of collision with vehicles in the blind-spot is detected.

Smart Cruise Control (SCC)

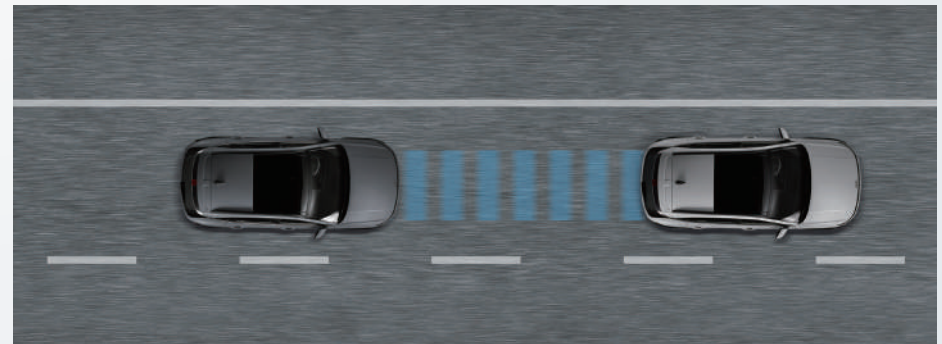

SCC helps maintain distance from the vehicle ahead and drive at a speed set by the driver while driving. The distance range can be selected in steps 1 to 4. The car drives automatically at the set speed while maintaining the distance from the vehicle ahead.

Safe Exit Warning (SEW)

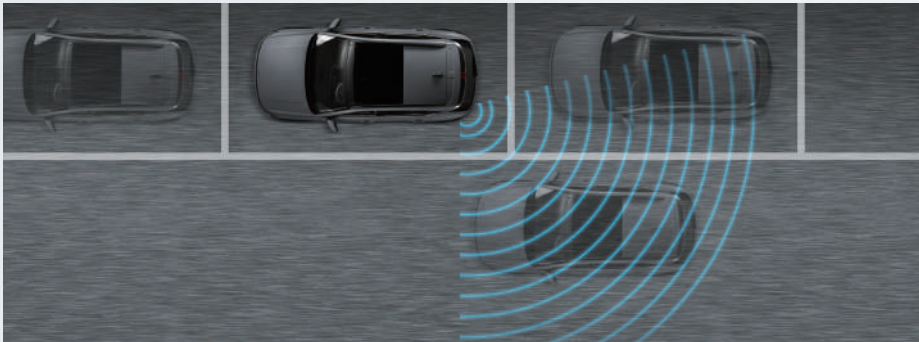

After the vehicle comes to a stop, if a car is approaching from the rear when a door is being opened, SEW will alert the driver and occupants with a warning sound, a blinking light on the outside view mirror, and a warning message in the gauge cluster.

Driver Attention Warning (DAW)



To prevent traffic accidents, DAW detects careless driving patterns caused by the driver's fatigue/inattentive driving and calls the driver's attention with cluster indication and alarm sound.

High Beam Assist (HBA)



When the system detects the headlights of oncoming cars or the tail light of vehicles in front, it will turn off the high beam to prevent the glare of other cars.

Blind-Spot View Monitor (BVM)



Linked with turn signal operation, BVM provides the driver with a video image of blind spots in the outside mirror.

Features that assist in safe and convenient parking through warning or active assistance control



Surround View Monitor (SVM)

SVM displays the surrounding view while driving and parking. Synthesized images from 4 wide view cameras show the surrounding view in various view modes including the changeable 360 3D View. Provides the feature to transmit the surrounding view of the vehicle to a smartphone

SVM Operating Scenario

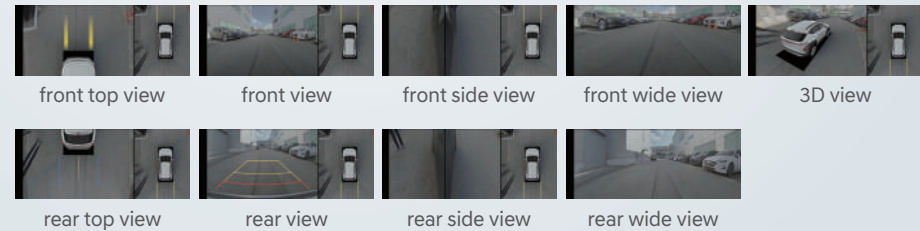

Rear View Monitor (RVM)

RVM displays the rear view while driving and parking. Using the rear view camera, shows the rear view and parking guidelines. Shows rear top view for parking and trailer hooking. Provides rear wide view.



Reverse Parking Collision-Avoidance Assist (PCA)

Warns if the risk of collision with rear pedestrians or objects around the vehicle is detected during parking and exiting. Automatically assists with emergency braking if the risk of collision increases after warning. Automatically turns on the Forward/Side/Reverse Parking Distance Warning.

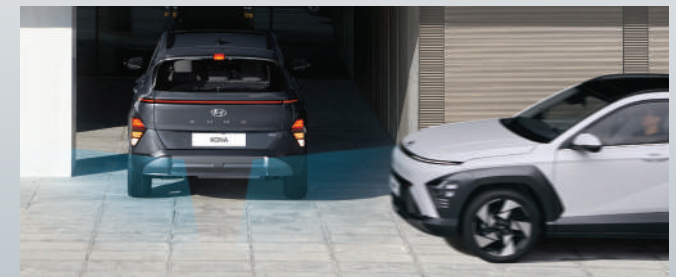

Rear Cross-Traffic Collision-Avoidance Assist (RCCA)

Warns if the risk of collision with an oncoming vehicle from the left/right while reversing at low speeds is detected. Automatically assists with braking if the risk of collision increases after warning.

Remote Smart Parking Assist (RSPA)

※ Availability may differ by country & region



RSPA assists with remote parking or exiting from outside the vehicle. Using the ultrasonic sensor, searches for a parking space and automatically assists with steering, accelerating, decelerating and shifting. Automatic braking when an object is detected in vehicle's path. Provides Smart Parking/Exit feature while the driver is in the vehicle. Provides Remote Parking, Remote Operation feature while the driver is out of the vehicle.



How to use function

The driver aligns the vehicle in front of the space, shifts to P-range and presses and holds the parking/view button to turn on the function, then gets out and presses the forward/reverse button on the smart key to operate.

Forward/Side/Reverse Parking Distance Warning (PDW)

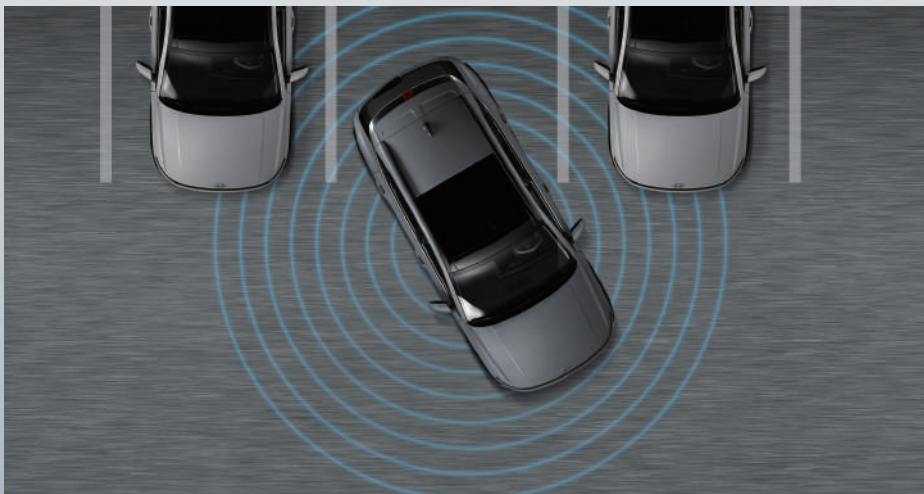

PDW provides warning to avoid collision with pedestrians and objects around the vehicle while parking or exiting. Warns the distance to pedestrians or objects close to the vehicle in 3 steps.

Cluster warning graphics

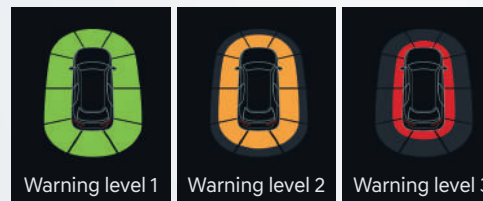

Warning level 1

Warning level 2

Warning level 3

CONVENIENCE



INFOTAINMENT SYSTEM	49
NEW FEATURES	50
CONVENIENT FEATURES	51

ccNC infotainment system



Hyundai Motor Company's next-generation infotainment system, ccNC, is equipped with new connected car technology and a more luxurious and refined GUI, providing superior interior luxury and user convenience.

Enlarged monitor size	12.3-inch (Cluster) + 12.3-inch (AVNT)
Theme unification between AVNT and cluster	Improved visual unity
Improving voice recognition usability	Provides various natural language-based voice recognition services

New Concept GUI (Graphical User Interface)

Improved sense of unity by applying a new GUI unified to navigation, cluster, and HUD

Graphic



Eliminate decorative elements and enhance information awareness and graphic integrity through simple & flat styles

Color



Harmony of calm low-saturation and intense accent color considering the day/night driving experience and display characteristics

Imagery

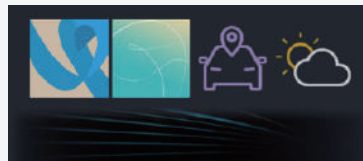
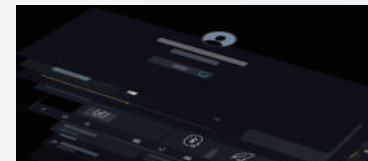

Image elements with motifs of linear elements in line with the brand concept (Seamless Horizon)

Layout



Application of grid system for consistent user experience

Animation

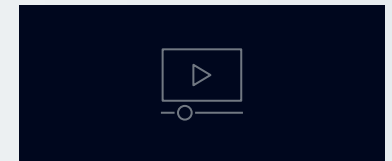

Extensive application of animation as a function for the role of intuitive delivery of information during UI manipulation

Smart power tailgate

The tailgate can be opened and closed with a button operation or smart key, providing convenience when loading and unloading cargo.



Tailgate height setting function through AVN

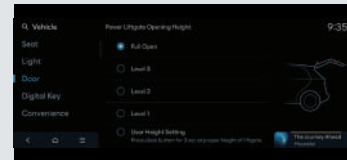
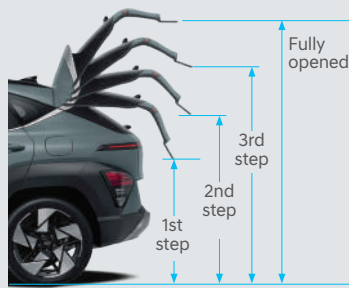

The opening height can be set through the AVN screen, such as 1st to 3rd, fully open, user height setting, etc.

User setting function of opening height



Manually position the tailgate at the desired height and press the close button for more than 3 seconds setting, etc.



BOSE premium sound system

Premium sound system that combines BOSE's unique technology with optimally tuned 8-speakers and an external amplifier



Rear Occupant Alert (ROA)

Rear occupant alert is a safety feature that alerts the driver to check the back seat of the vehicle for occupants after the ignition is turned off



Ambient mood lamp

The 64-color variable mood lamp provides various cabin atmospheres and enhances luxury and practicality with lighting effects in the storage area

Convenient features



Touch-type outside door handle



Roof rack



Safety power window



Sun roof



USB-C Data/Charging ports
/Wireless charging pad



Powered driver seat



Drive mode selector



Heated & Ventilated front seats



Heated rear seats



Crashpad open tray



LED room lamp



Seat back pocket



Rear seat center armrest



Rear airvent



Rear C-type USB power outlets

APPENDIX

Provides a body size optimized for urban SUVs, superior product competitiveness that surpasses competitors, and a lineup of interior and exterior colors that respond to customer tastes and unique lifestyles



COLOR GUIDE	53
DIMENSION	55

Total 10 colors (New 8 type, C/O 2 type)

		1	2	3	4	5	6	7	8	9	10
HMC Ulsan 1 Plant		NEW	C/O	C/O	NEW	NEW	NEW	NEW	NEW	NEW	NEW
											
Name		Abyss Black Pearl	Atlas White	Cyber Gray Metallic	Ecotronic Gray Pearl	Ultimate Red Metallic	Soultronic Orange Pearl	Neoteric Yellow	Mirage Green	Meta Blue Pearl	Denim Blue Pearl
Type		P	S	M	PM	PM	P	S	S	PM	PM
Code		A2B	SAW	C5G	PE2	R2P	SOP	YYY	RRR	PM2	TN6
2-tone Roof (A2B)		-	SA0	C50	PE0	R20	SO0	YY0	RR0	PM0	TN0
USA (K7)	ICE / HEV / EV	•	•	•	•	•	•	•	•	-	•
	N-LINE (All)	•	•	-	•	•	•	-	-	-	•
CAN (K6)	ICE / HEV / EV	•	•	•	•	•	•	•	•	•	•
	N-LINE (All)	•	•	•	•	•	•	•	•	•	•
EUR (K4)	HEV	•	•	•	•	•	•	•	•	•	•
	HEV N-LINE	•	•	•	•	•	•	•	•	•	•
AUS (K5)	ICE / HEV / EV	•	•	•	•	•	•	•	•	•	•
	N-LINE (All)	•	•	•	•	•	•	•	•	•	•
GEN (K2/3)	ICE / HEV / EV	•	•	•	•	•	•	•	•	•	•
	N-LINE (All)	•	•	•	•	•	•	•	•	•	•
Note		Non-2 tone roof	In 2 tone roof code : '0' is numeral								

Total 11 colors (New 8 type, C/O 3 type)

		1	2	3	4	5	6	7	8	9	10	11
HMC Ulsan 3 Plant		NEW	NEW	NEW	NEW	C/O	NEW	NEW	NEW	C/O	C/O	NEW
Name		Abyss Black Pearl	Atlas White	Serenity White Pearl	Shimmering Silver Metallic	Cyber Gray Metallic	Ecotronic Gray Pearl	Ultimate Red Metallic	Mirage Green	Amazon Gray Metallic	Demin Blue Pearl	Meta Blue Pearl
Type		P	S	P	M	M	PM	PM	S	M	P	PM
Code		A2B	SAW	W6H	R2T	C5G	PE2	R2P	RRR	A5G	TN6	PM2
2-tone Roof (A2B)		-	SAO	W60	RT0	C50	PE0	R20	RR0	A50	TN0	PM0
EUR (K4)	ICE	•	•	•	•	•	•	•	•	•	•	•
	ICE N-LINE	•	•	•	•	•	•	•	•	•	•	•
Note		Non-2 tone roof		In 2 tone roof code : '0' is numeral								

Total 11 colors (New 7 type, C/O 4 type)

		1	2	3	4	5	6	7	8	9	10	11
HMC Czech Plant		NEW	C/O	C/O	C/O	NEW	C/O	NEW	NEW	NX4 New	NX4 New	NEW
Name		Abyss Black Pearl	Atlas White	Serenity White Pearl	Shimmering Silver Metallic	Ecotronic Gray Pearl	Engine Red	Ultimate Red Metallic	Jupiter Orange Metallic	Hunter Green Pearl	Sailing Blue Pearl	Meta Blue Pearl
Type		P	S	P	M	PM	S	PM	PM	P	P	PM
Code		A2B	SAW	W6H	R2T	PE2	JHR	R1P	PL2	T2P	U2P	PM2
2-tone Roof (A2B)		-	SAO	W60	R24	PE0	JH0	R10	PL0	T20	U20	PM0
EUR (K4)	EV	•	•	•	•	•	•	•	•	•	•	•
	EV N-LINE	•	•	•	•	•	•	•	•	•	•	•
Note		Non-2 tone roof		In 2 tone roof code : '0' is numeral								



Unit: mm

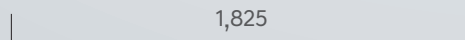

1,580
[w/ Roof rack : 1,615]

A vertical dimension line to the right of the rear view indicates a height of 1,580 mm. A note below it states "[w/ Roof rack : 1,615]".

Global Product Planning Team 1
Hyundai Motor Company

12 Heolleung-ro(231 Yangjae-dong),
Seocho-gu, Seoul, 137-938, Korea
Tel : 82-2-3464-0839

www.hyundai.com

※ Details may vary depending on the manufacturing plant and body type.

Photos, specifications, features and equipment shown in this publication are based upon the latest available information. Hyundai Motor Company reserves the right to make changes at any time, without notice or obligation, to the specifications and materials on all models. Use for any other purpose including public dissemination is strictly forbidden.

※ This product guide is to be used for internal purposes only.

Copyright © 2023 Hyundai Motor Company. All Rights Reserved.